

# Physics 3AB

## Motion and Forces Test One 2013

Name:

Mark: / 67

= %

### Notes to Students:

- You must include **all** working to be awarded full marks for a question.
- Marks will be deducted for incorrect or absent units and answers stated to an incorrect number of significant figures.
- **No** graphics calculators are permitted – scientific calculators only.

**Question 1****(13 marks)**

By banking the curves of racetracks it is possible for vehicles to turn in a horizontal circle without relying on friction. For a car of mass  $1.70 \times 10^3$  kg the angle of banking is set at  $13.4^\circ$  above the horizontal. The curve has a radius of 171 m and the car drives at a speed to maintain its height.

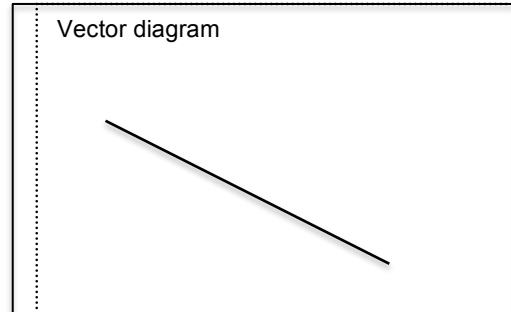
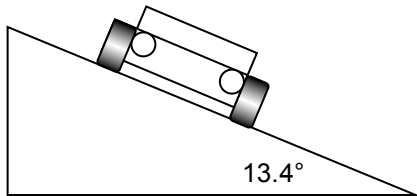

- (a) Draw a vector diagram showing (and labelling) the forces acting on the car in the space indicated above. (2 marks)
- (b) Calculate the magnitude of the centripetal force acting on the car. (5 marks)
- (c) Determine the speed of the car in  $\text{kmh}^{-1}$ . (3 marks)

(d) Explain why a banked curve would be safer in wet conditions.

(3 marks)

**Question 2**

(4 marks)

Calculate the deceleration of a snow boarder going up at  $5.00^\circ$  slope. Assume the coefficient of friction ( $\mu_k$ ) for waxed wood on wet snow is 0.1.

$$F_f = \mu_k F_N.$$

**Question 3****(5 marks)**

During a game of totem tennis a ball of mass 60.0 g swings freely in a horizontal circular path. The string is 1.30 m long and is at an angle of  $30.0^\circ$  to the vertical as shown in the diagram.

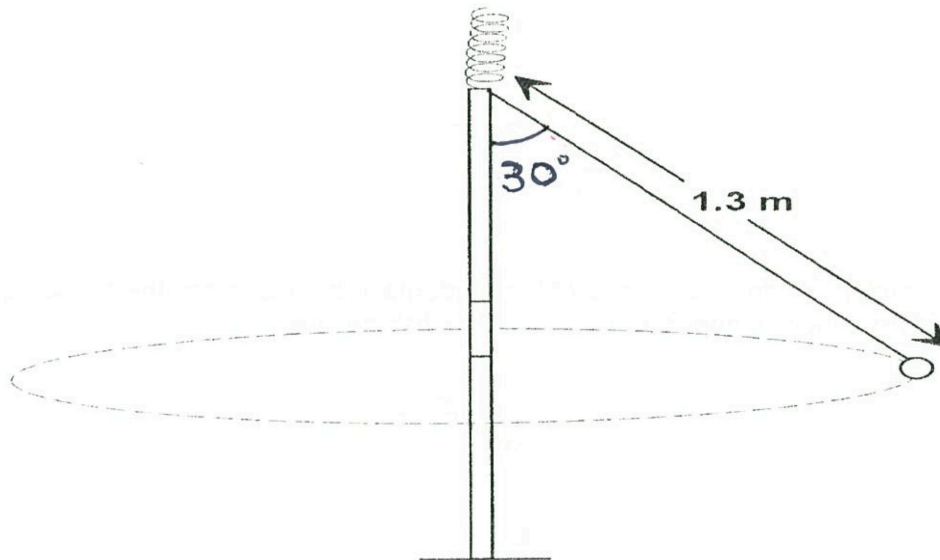

(a) Calculate the radius of the ball's circular path.

**(2 marks)**

(b) Calculate the tension in the string.

**(3 marks)**

**Question 4**

**(5 marks)**

To demonstrate circular motion to her students, a Physics teacher attached a 40.0 g rubber stopper to a length of fishing line and spun it clockwise in a horizontal circle when viewed from above.

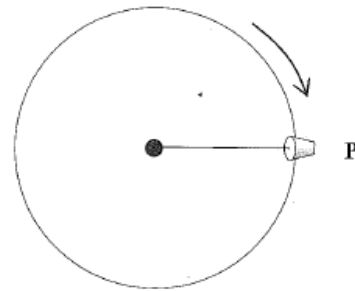

- (a) If the rubber stopper completes a horizontal circle of radius 50.0 cm in 0.800 s, what is the magnitude of the tension in the fishing line?

**(4 marks)**

At one instant in the motion, one of the students in the class has the following side-view of the rubber stopper and length of the fishing line.

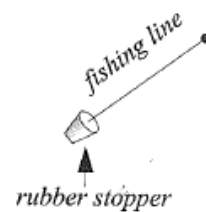

- (b) At this instant, the forces (ignoring friction) acting on the stopper would be:

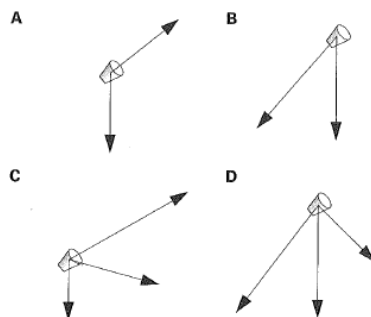

Answer: \_\_\_\_\_

**(1 mark)**

**Question 5****(21 marks)**

A student arranges a toy car track with a vertical loop of radius 30.0 cm, as shown. A car of mass 250 g is pushed, with an initial speed of  $2.00 \text{ ms}^{-1}$ , from a height of 1.50 m at point X. The car moves down the track and travels around the loop. Ignoring friction answer the following questions.

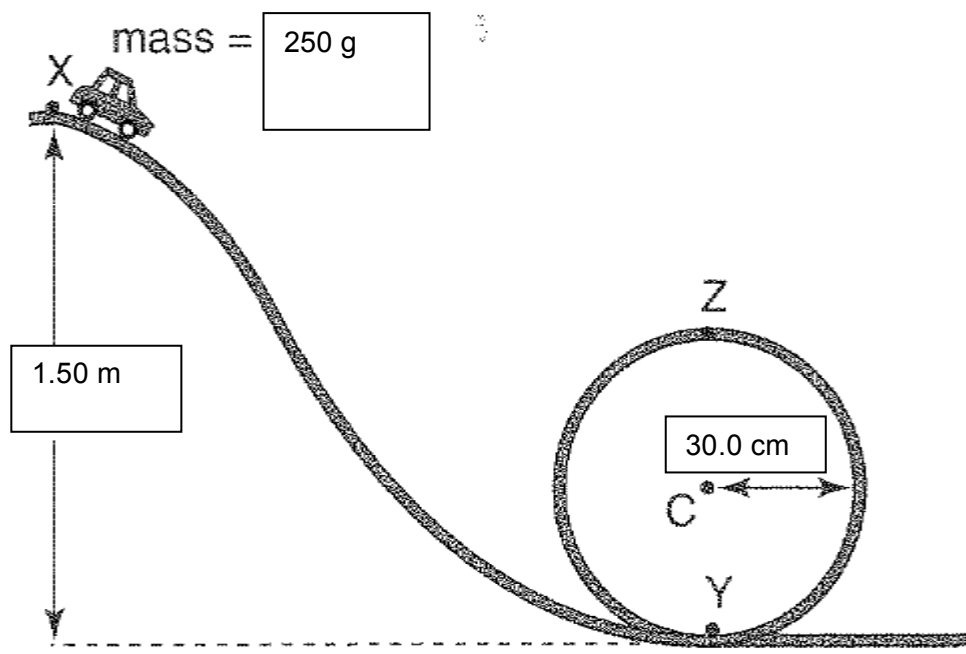

- (a) Calculate the speed of the car as it reaches the bottom of the loop at point Y. (3 marks)

- (b) Determine the centripetal acceleration of the car at point Y. (3 marks)

(c) Determine the force of the track on the car at point Y. (4 marks)

(d) Determine the minimum speed required by the car to maintain its circular path and not fall off the track. (4 marks)

(e) Will the car make the loop? Justify your answer with appropriate calculation/s. (4 marks)

- (f) Where will the passengers 'feel' the heaviest? Explain your answer. (3 marks)

**Question 6**

**(4 marks)**

A rally driver approaches a corner at  $90.0 \text{ kmh}^{-1}$  North and turns out of it at  $75.0 \text{ kmh}^{-1}$  West. What is the change in velocity of the driver? Include a labelled diagram showing the change in velocity.



**Question 7****(15 marks)**

An eagle has captured a fish and is 14.7 m directly above the water when it releases the fish. The eagle is moving with a velocity of  $5.20 \text{ m s}^{-1}$  at an angle of  $36.6^\circ$  above the horizontal when the fish is released. Ignore air resistance for calculations.

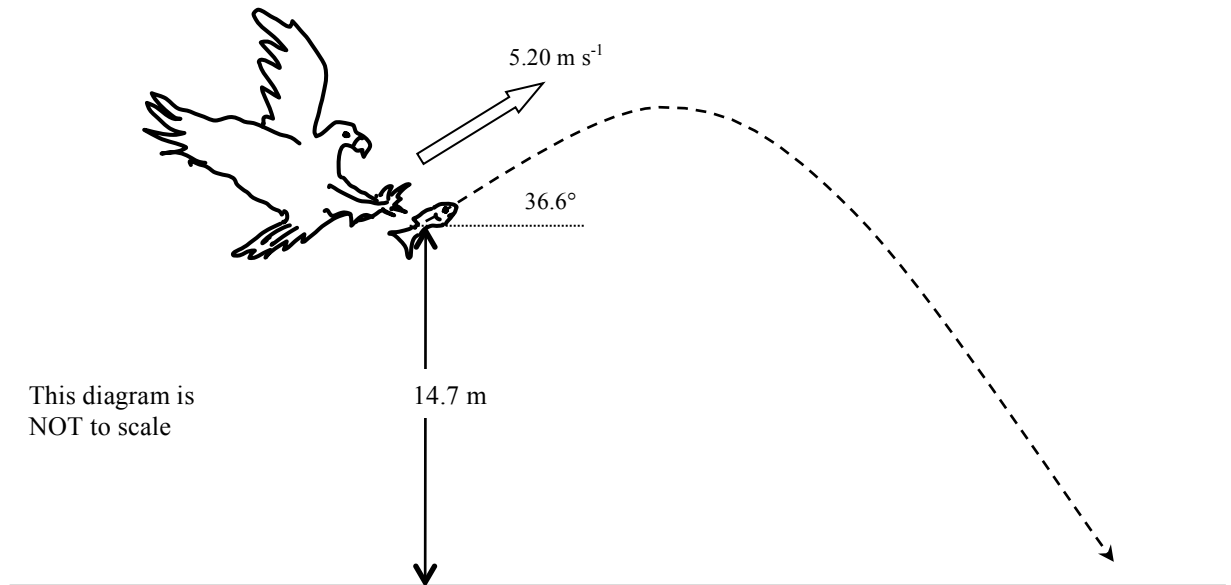

- (a) Calculate the time taken for the fish to reach the water.

**(3 marks)**

- (b) Calculate the horizontal distance that the fish travels during its flight back to the water.

**(3 marks)**

(c) Calculate the maximum height above the water that the fish reaches during its flight.

(4 marks)

(d) Determine the final speed of the fish before it hits the water.

(5 marks)